

LINKA BUILDING KIT

LINKA

COUNTRY INN

Designer: Richard Young

Before building this model do become familiar with casting, gluing, and cutting parts, as shown in the "Basic Instructions".

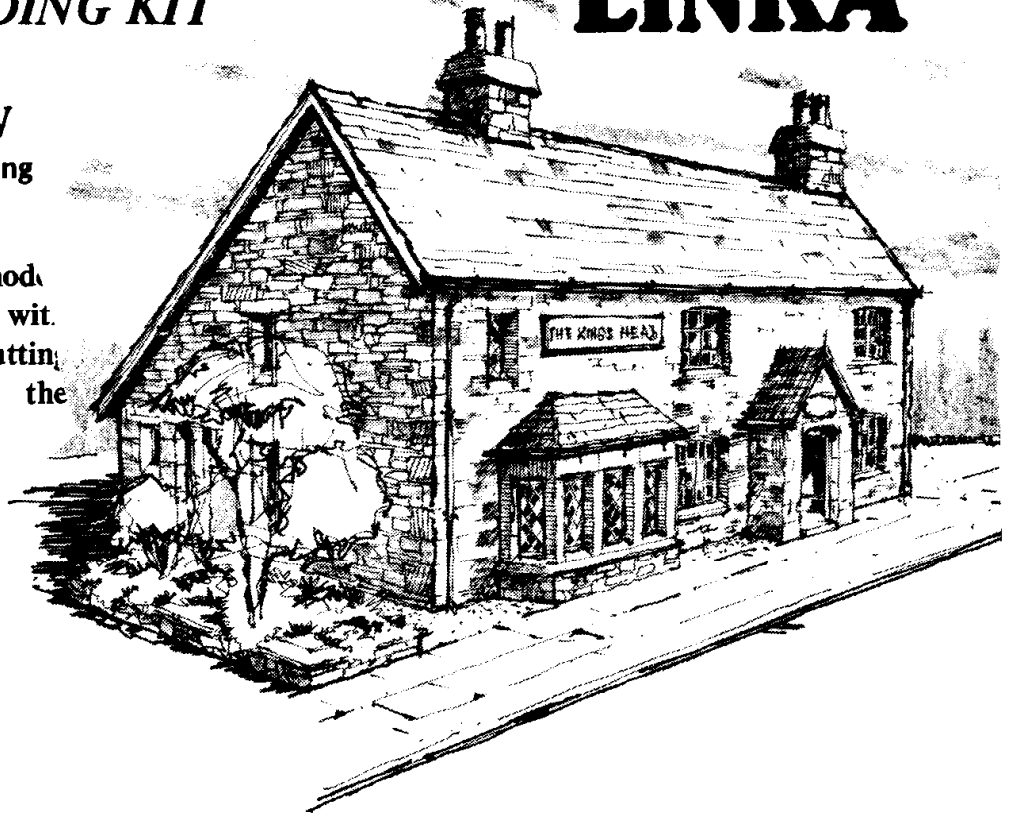

PARTS NEEDED:

There are five moulds in this set. Cast each mould as shown below:

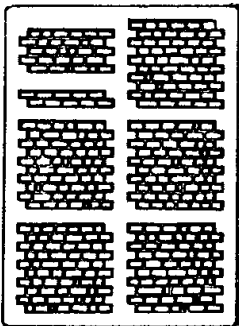

CAST S1 FIVE TIMES

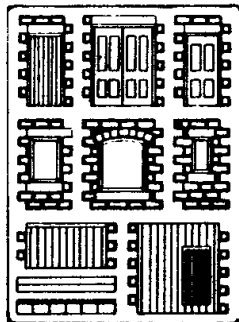

CAST S2 SIX TIMES

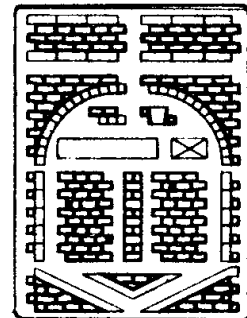

CAST S3 SIX TIMES

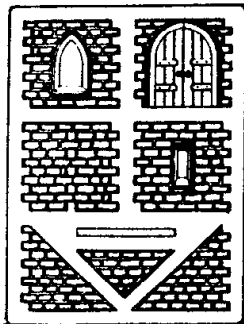

CAST S4 FIVE TIMES

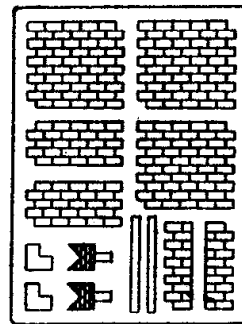

CAST R1 SEVEN TIMES

This will produce all the castings needed for this model, as well as a number of spare parts. These spare parts are useful in case you accidentally break any parts during construction, as well as providing extra parts for any variations you may choose to add.

BUILDING THE MAIN WALLS:

1) Using the castings shown below, glue the front wall together. When the wall is complete, place face down onto a flat working surface and press all the castings into good alignment before leaving to set. This final lining up of each wall is important, for poor alignment will show up on the finished model.

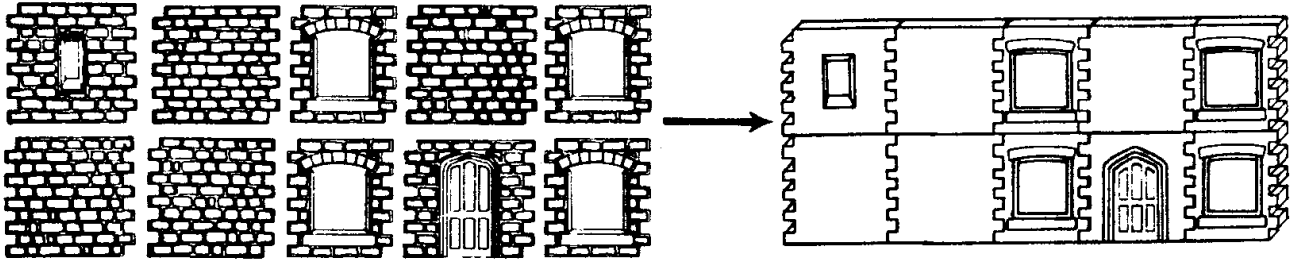

2) Glue the left-hand wall together.

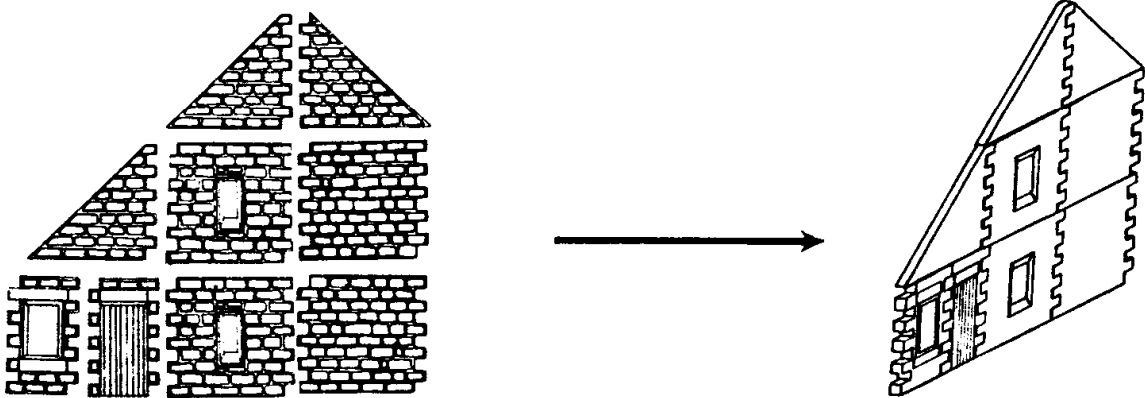

3) Glue the right-hand wall together.

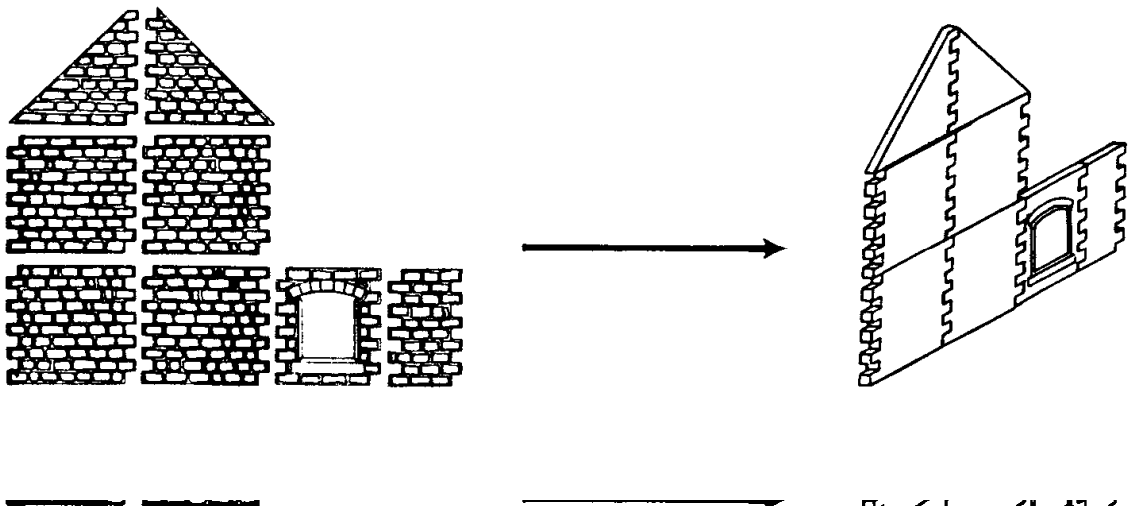

4) Glue the back wall together, cutting off lower left-hand teeth, as shown below.

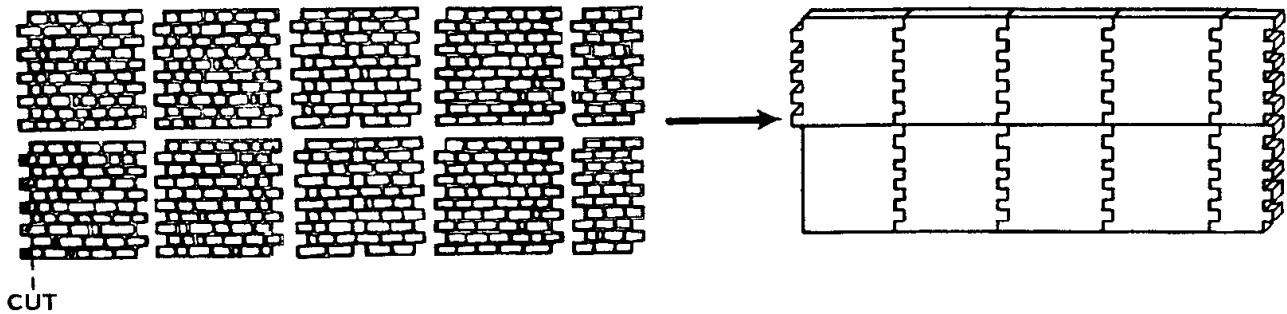

5) Add a small extension at right-angles to the back wall, as shown below.

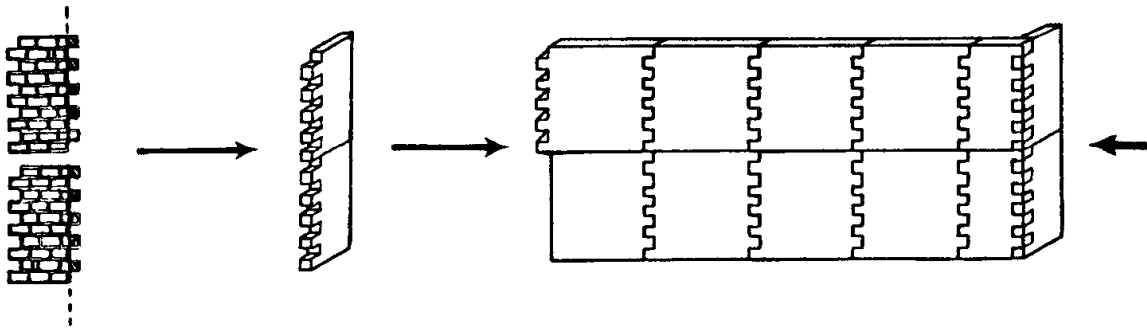

6) When set, glue the two side walls to the front wall, one wall at a time, carefully easing the teeth from one wall into another. Try to be careful; but don't worry if some teeth break off during this tricky operation, as broken teeth can be glued back into place. (Any fracture line will become invisible after the model has been painted.)

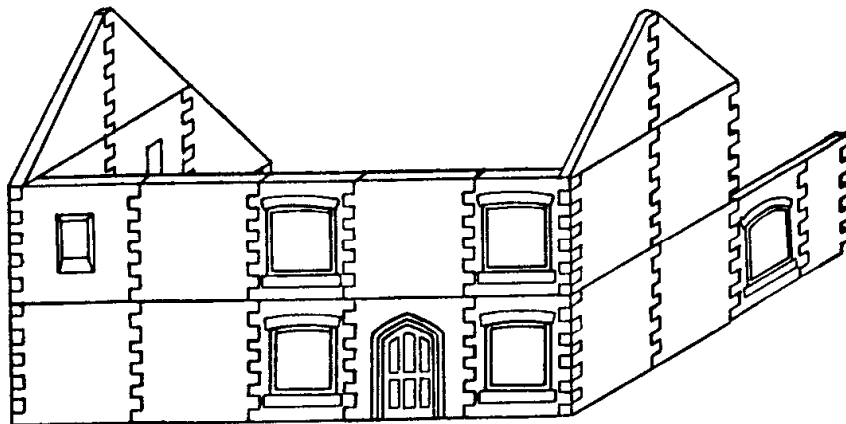

4

7) Glue the back wall in place, carefully locating as shown below, so that the side walls extend past the back wall, ready for the rear buildings.

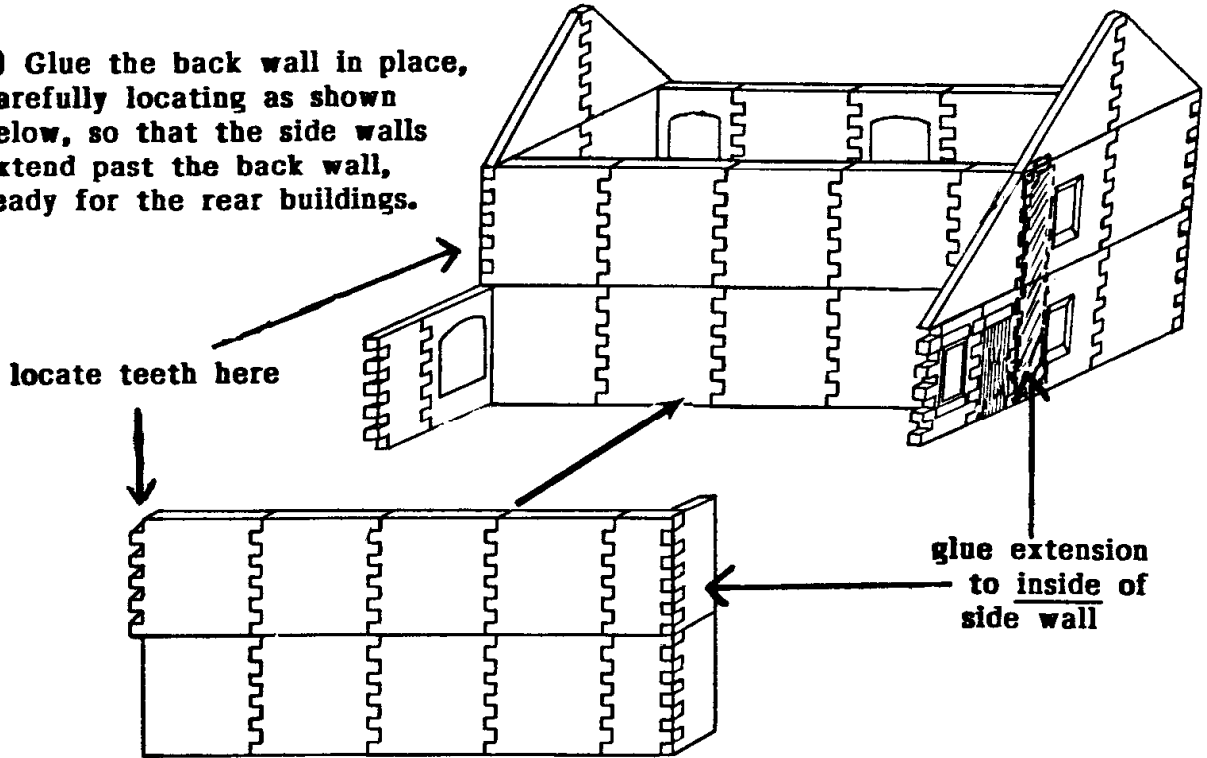

BUILDING THE REAR BUILDINGS:

1) Using the castings shown below, glue the rear gable wall together.

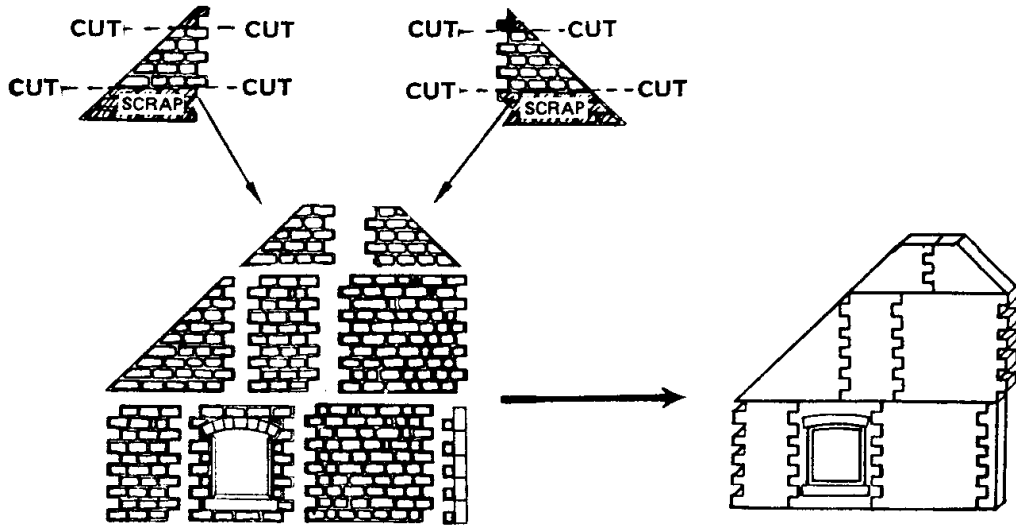

2) Glue the rear side wall together.

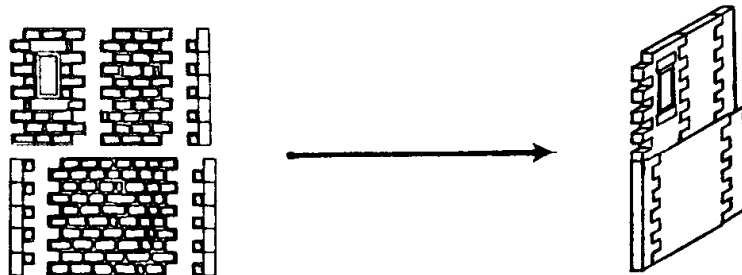

5

3) When set, glue these two walls together; then glue them in place on the main model as shown below.

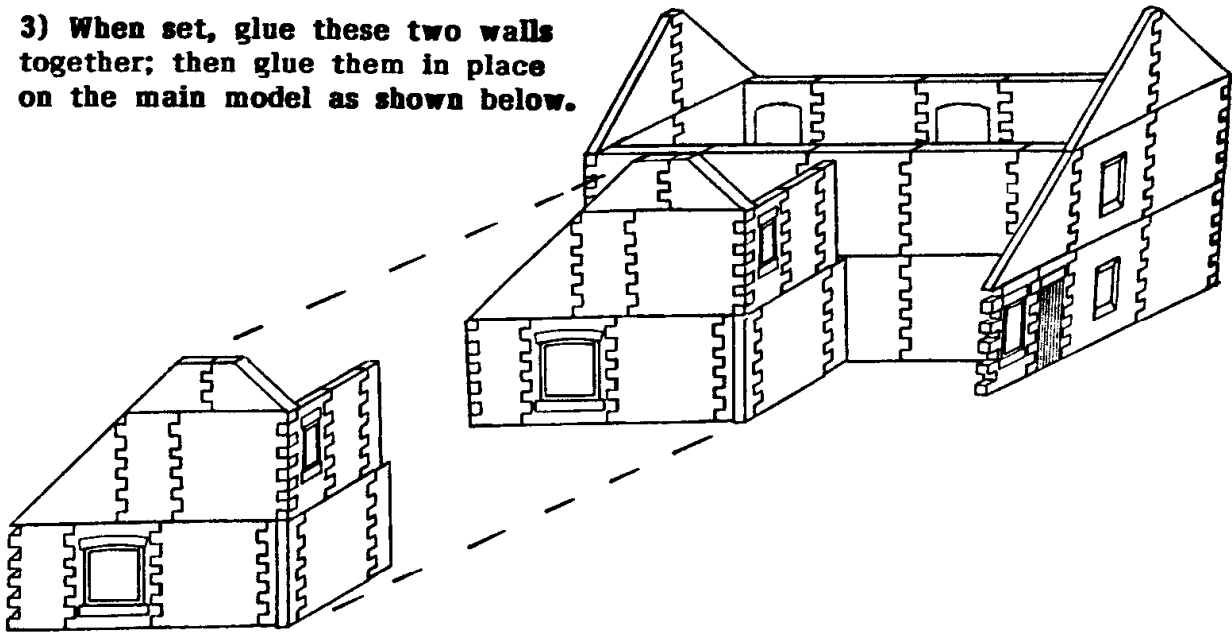

4) Glue the rear low wall together.



5) Add an inner corner from a single casting, as shown below.



6) When set, glue this final piece in place.



BUILDING THE REAR CHIMNEY:

1) Glue the main chimney breast together, cutting the bottom casting diagonally, as shown on the diagram.

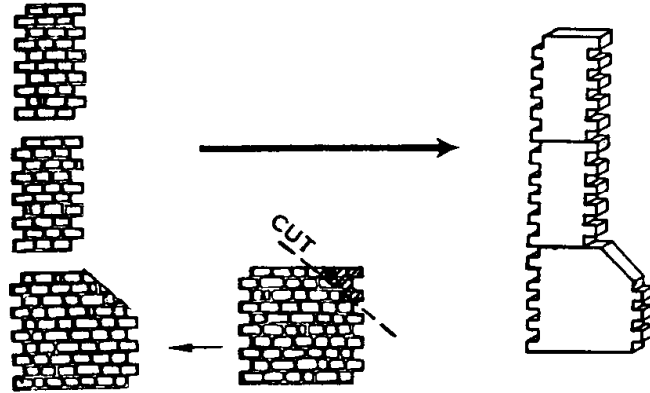

2) Add the chimney breast sides, as shown below, using castings from mould S3 cut in half.

a) Cut three S3 castings in half.



b) Cut two of these half-castings as shown.

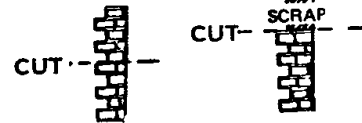

c) Using these cut castings, add the chimney breast sides.

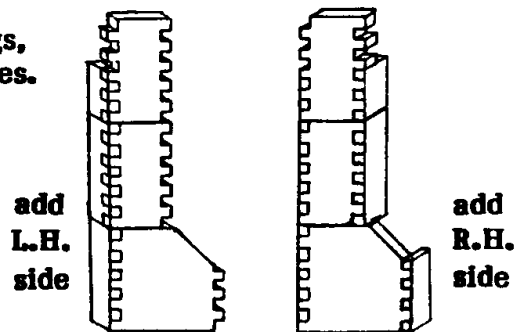

3) Glue the three castings shown below to the top of the chimney breast to form a square.

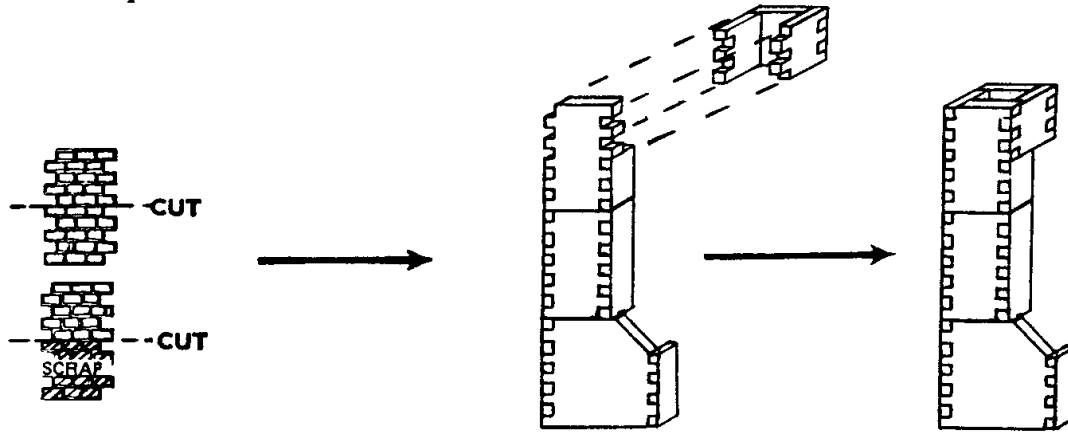

4) Add the lower breast cap. This is made from an S3 casting, cut and chamfered as shown below. (Take your time - this is a tricky little operation.)

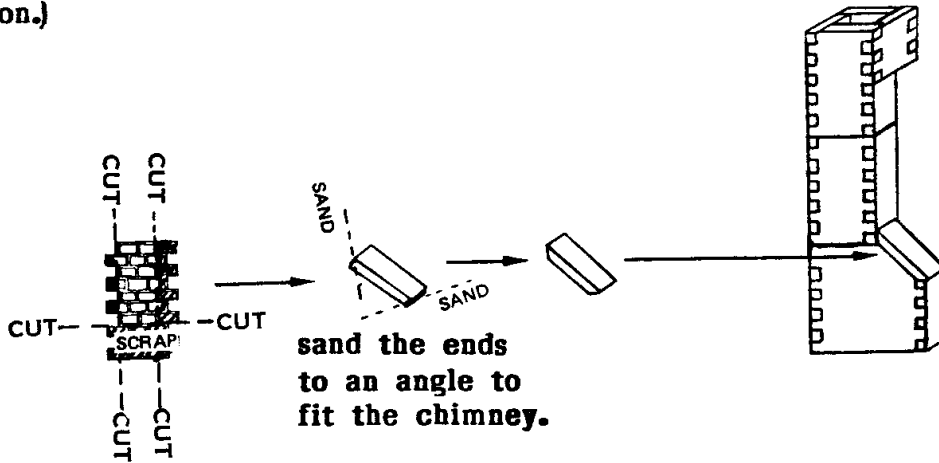

When in place, scribe in the mortar lines as needed. If done carefully, this piece will merge with the rest of the chimney.

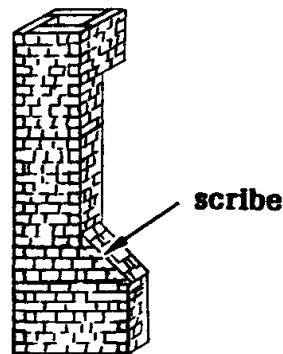

5) Cut and sand a single casting as shown below, and glue in place, smooth side uppermost, to form the top of the chimney.

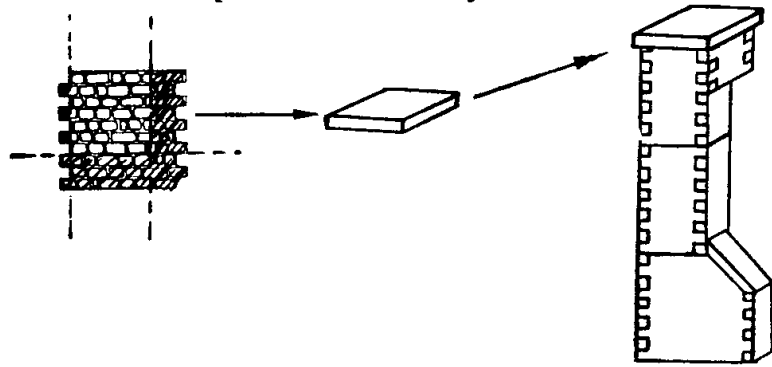

6) Glue the chimney breast in place onto rear gable wall.

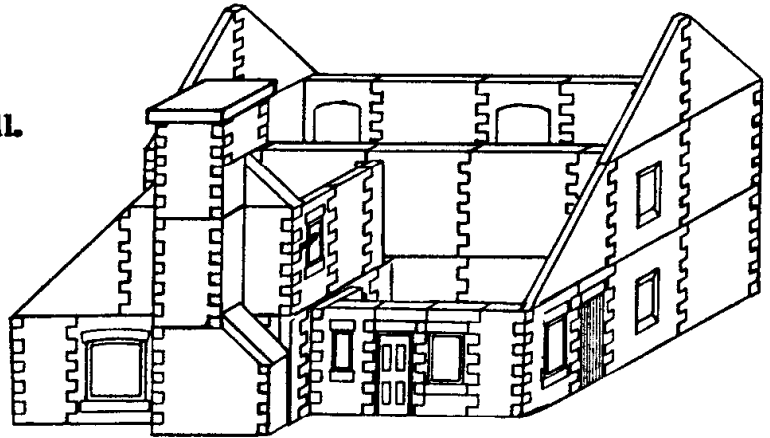

ADDING THE MAIN ROOF:

1) Glue the front roof together.

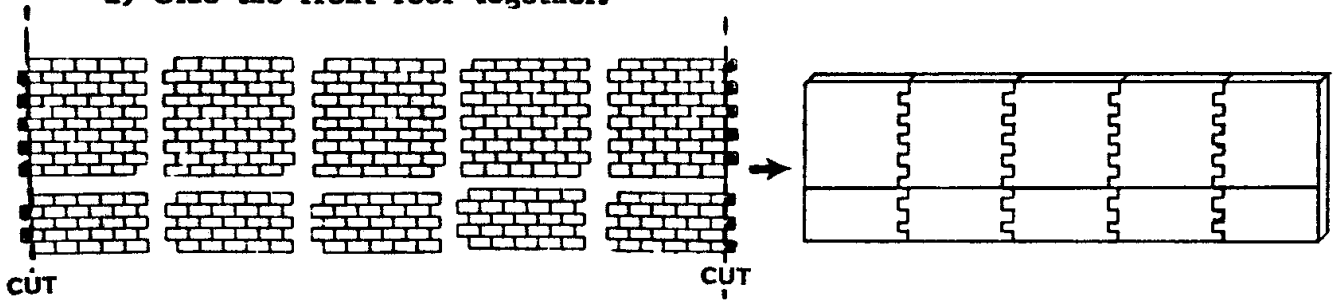

2) Glue the upper rear roof together.

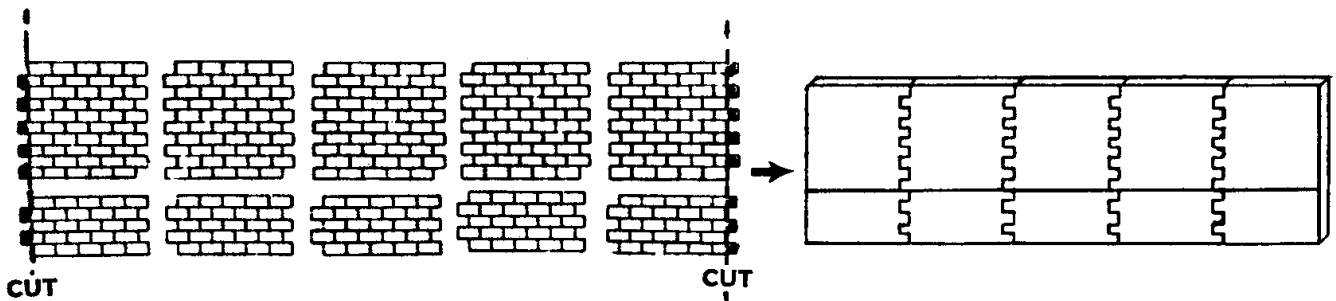

3) When set, glue both roof parts in place on the main walls.

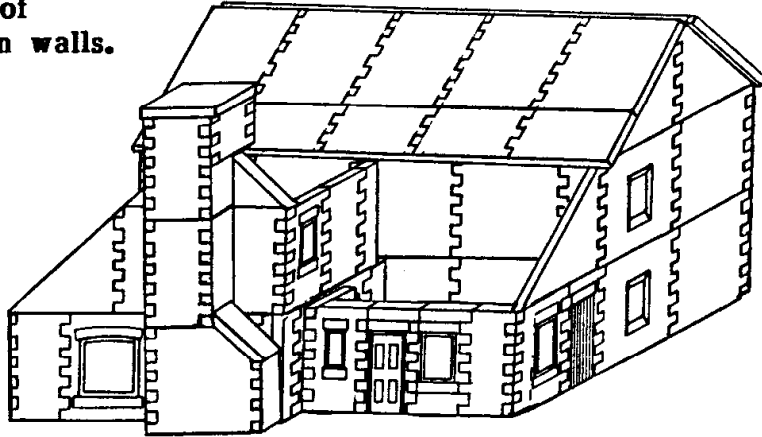

4) Glue the lower rear roof together.

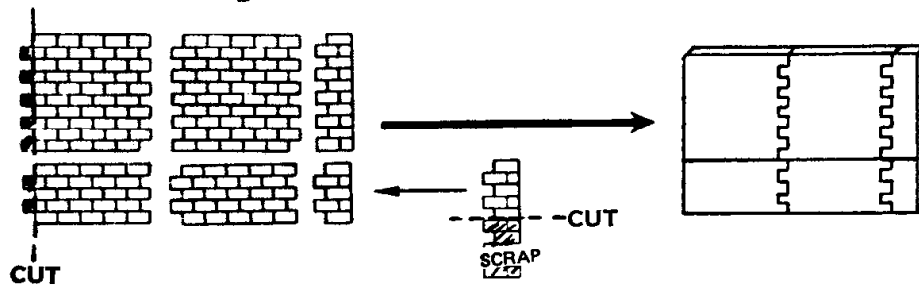

5) When set, glue in place, aligning exactly with the main roof.

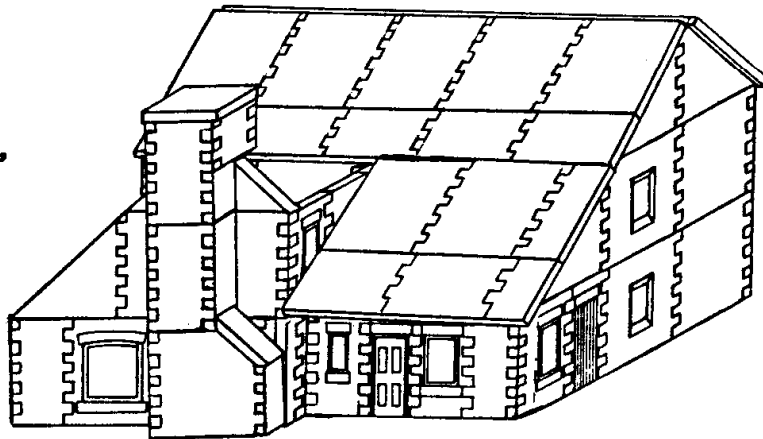

6) Add the square roof ridge parts (from mould R1) to the apex.

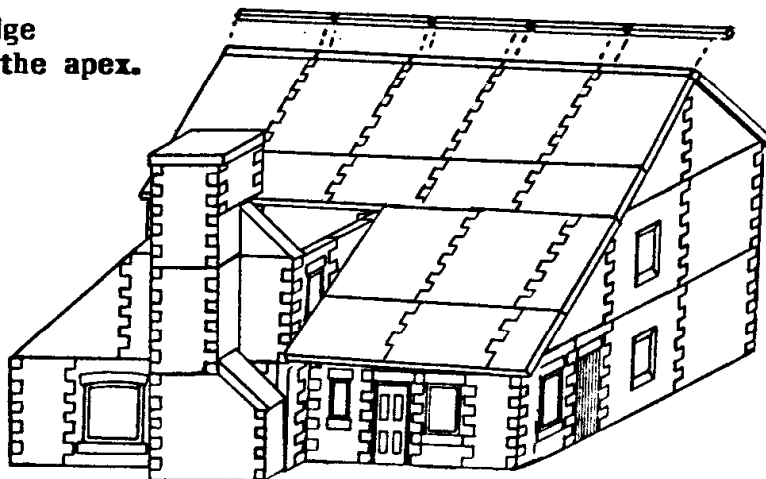

ADDING THE REAR ROOF:

1) Glue the left-hand rear roof together.

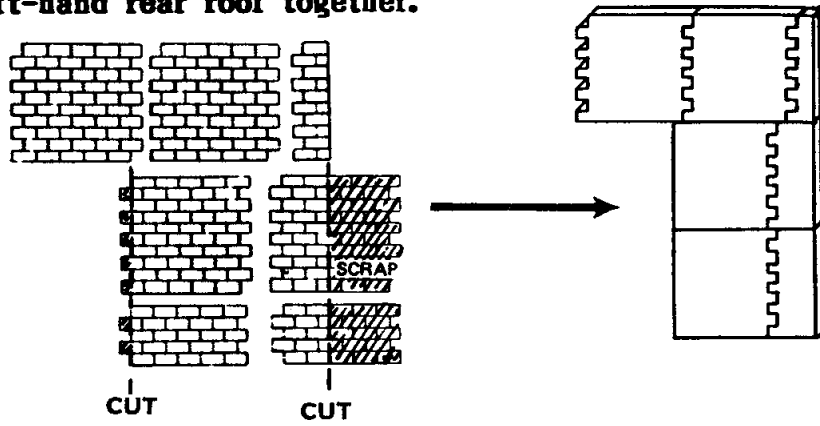

**2) When set, cut as shown.
(Count the tiles to find
the exact place for the cuts.)**

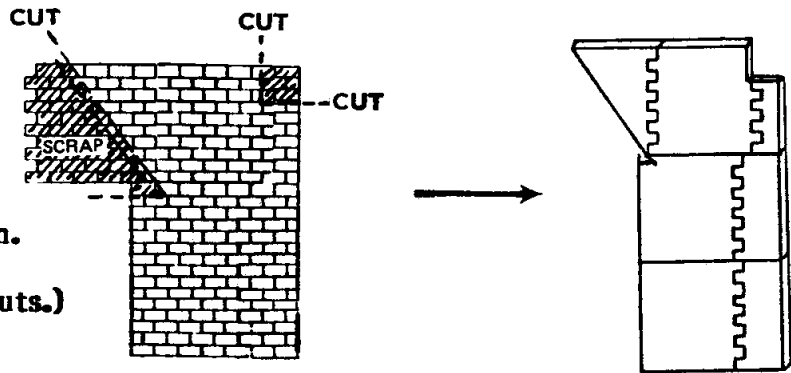

**3) Glue the right-hand
rear roof together.**

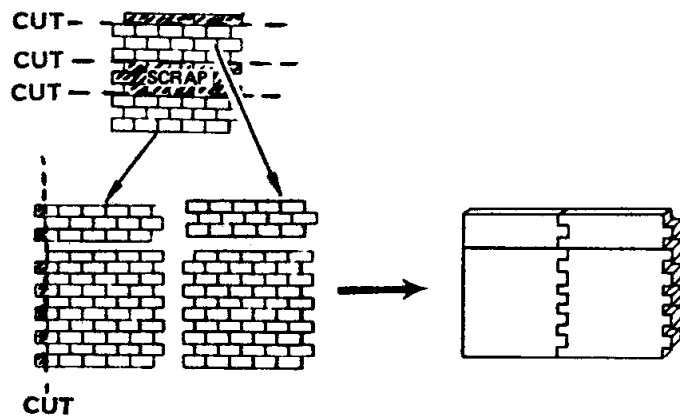

4) When set, cut as shown.

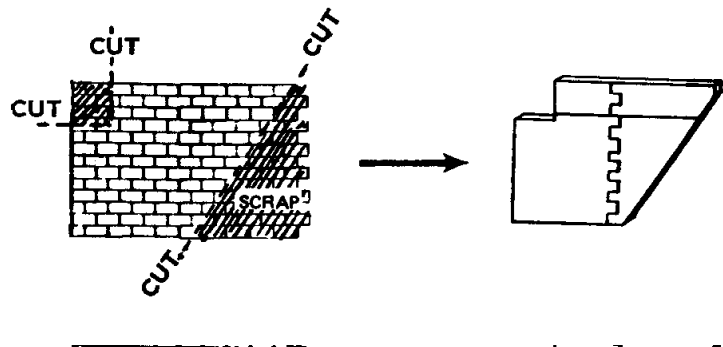

5) Carefully glue both rear roofs in place around the rear chimney.

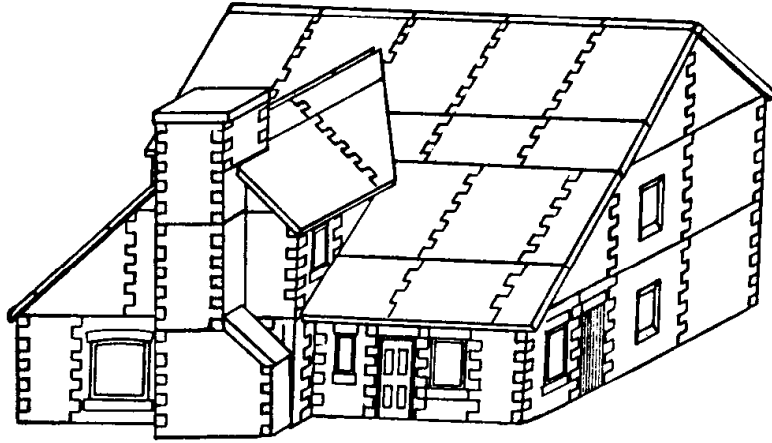

6) Add the square roof ridge parts to the apex.

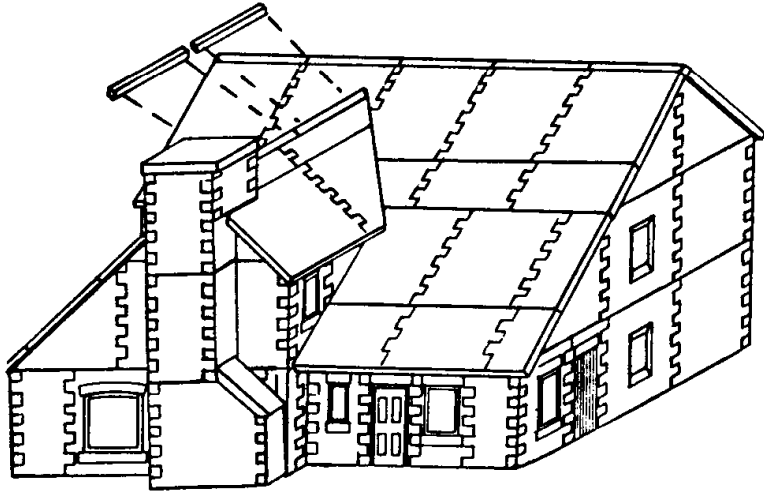

7) There will be a gap where the rear roof meets the main roof. This gap should be filled by carefully painting in a weak mix of Linka moulding compound (about 2 parts water to 1 part compound) along the gap and smoothing down with a finger. Fill any gap around the rear chimney with the same method.

ADDING CHIMNEYS:**(These parts are supplied complete)**

- 1) Glue both chimney stacks in place on the main roof.
- 2) Glue the rear upper chimney stack in place.
- 3) Glue the chimney tops to each of the three chimney stacks.
- 4) Glue the chimney pots in place.

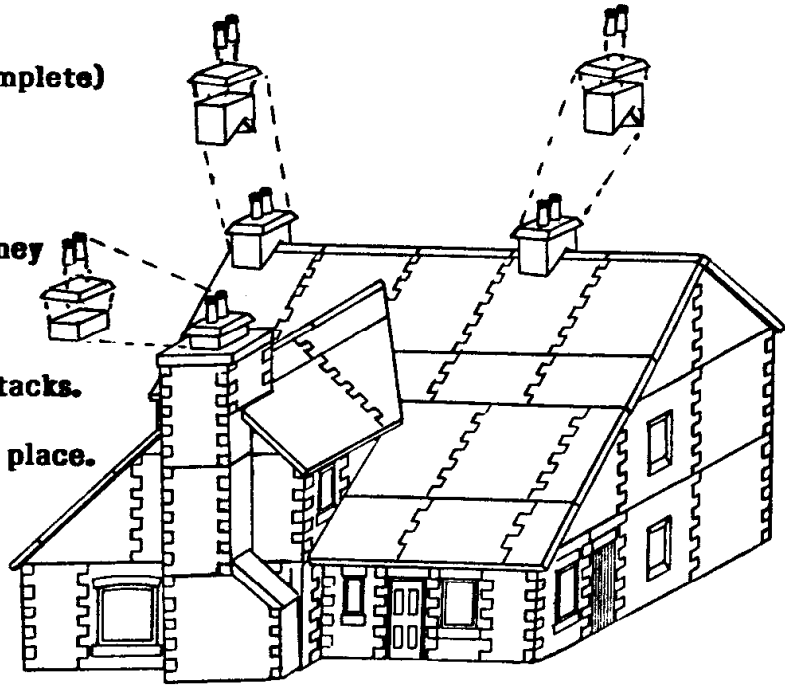
**ADDING THE BAY WINDOW, PORCH, AND SIGN:**

Glue in place on the front of the building, as shown below.

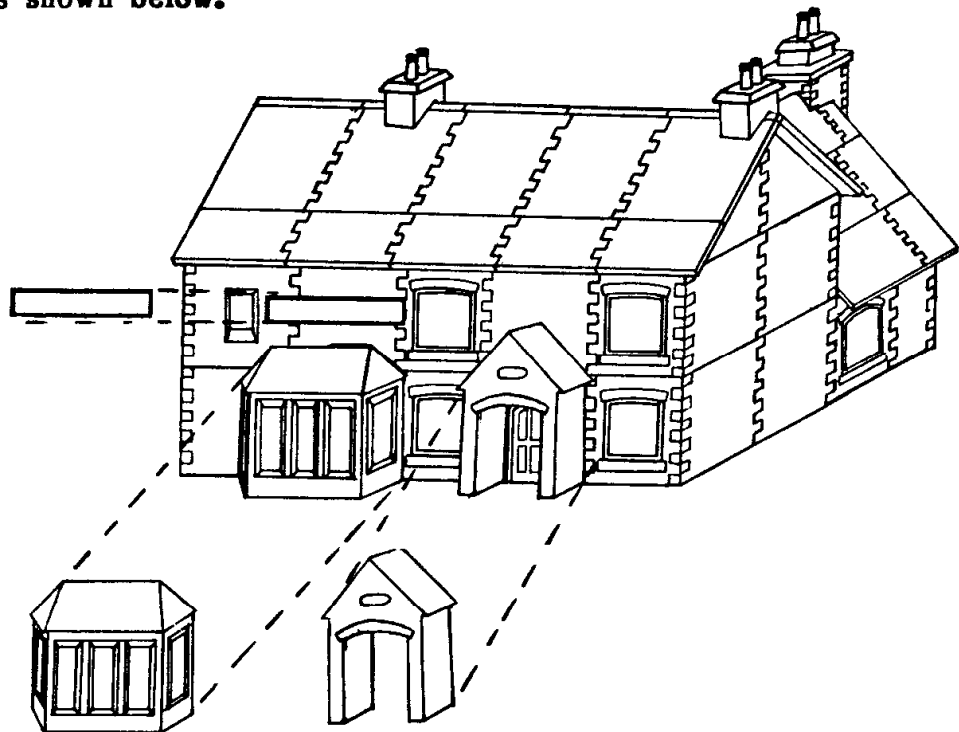

PAINTING AND ADDING WINDOWS:

The model is now ready for painting. Many model paints can be used for painting Linka models, with pots of enamel or acrylic paints (such as "Humbrol", available from most model and craft stores) being popular. For brick and stonework, etc, use a matt paint; for doors, window frames, gutters, drainpipes, etc., use a gloss paint.

You should find the painting both interesting and straightforward, as the castings take paint well, with the crisp detail helping to guide your brush.

The exact shades and colours to be used are up to you, as stone and slate vary greatly in hue. You may find it helpful to refer to the coloured illustration on the box. A colour guide is also included in this kit.

1) Paint all stonework with your chosen stone colour, then all roofing with your chosen slate colour. Paint the windows on the bay window silver, and when dry, lightly paint the lattice black to give a leaded window effect.

2) Once this first coat of paint is dry, check the model for any gaps or ill fitting joints. Fill any gaps by making a very weak mix of Linka moulding compound (about $\frac{1}{2}$ teaspoonful of compound to 3 teaspoonsful of water) and paint this mix into the gaps with a small paintbrush. An old toothbrush is useful for cleaning off any excess mix, as well as cleaning out any detail that may have been inadvertently covered. Repaint with stone or slate colour as needed.

3) Decide on your colour scheme and, using gloss paint, paint the doors and signboard the colour chosen. Paint the window frames gloss white. Paint the chimney pots matt dark yellow.

4) When dry, cut out windows from the window sheet supplied, and glue in place behind the window apertures of the model. Try to keep the surfaces of the windows free from glue. Cut out the pub name from the sheet supplied, and glue in place on the signboard.



5) For greater realism, pick out various stones in different shades of stone colour: mix a little palette of stone colour, then add small dabs of red or yellow to give different shades of stone. This can be applied at random to various stones around the model. Do this two or three times with different shades. Repeat the process with varying shades of slate colour on the roof.

ADDING GUTTERS AND DRAINPIPES:

1) Prepare the underside of the front roof for guttering by sanding the bottom edge horizontal, as shown below. (You may find that carving with a craft knife, and then sanding, speeds up this task.)

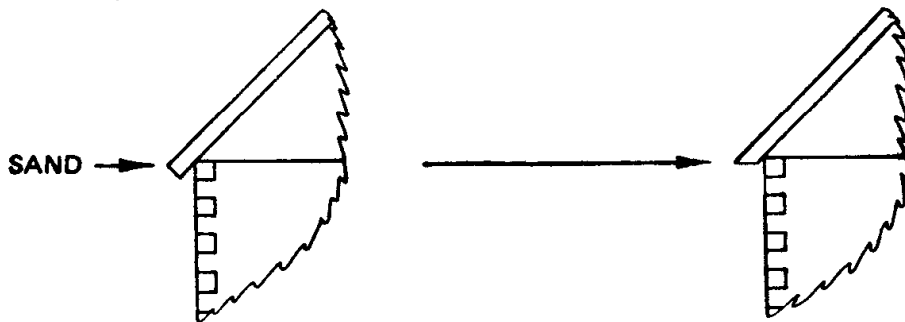

2) Cut a piece of plastic guttering to the length of the front roof; then glue in place under the eaves.

3) Cut two pieces of plastic drainpipe to the height of the front wall; bend as shown; then glue in place under the guttering.

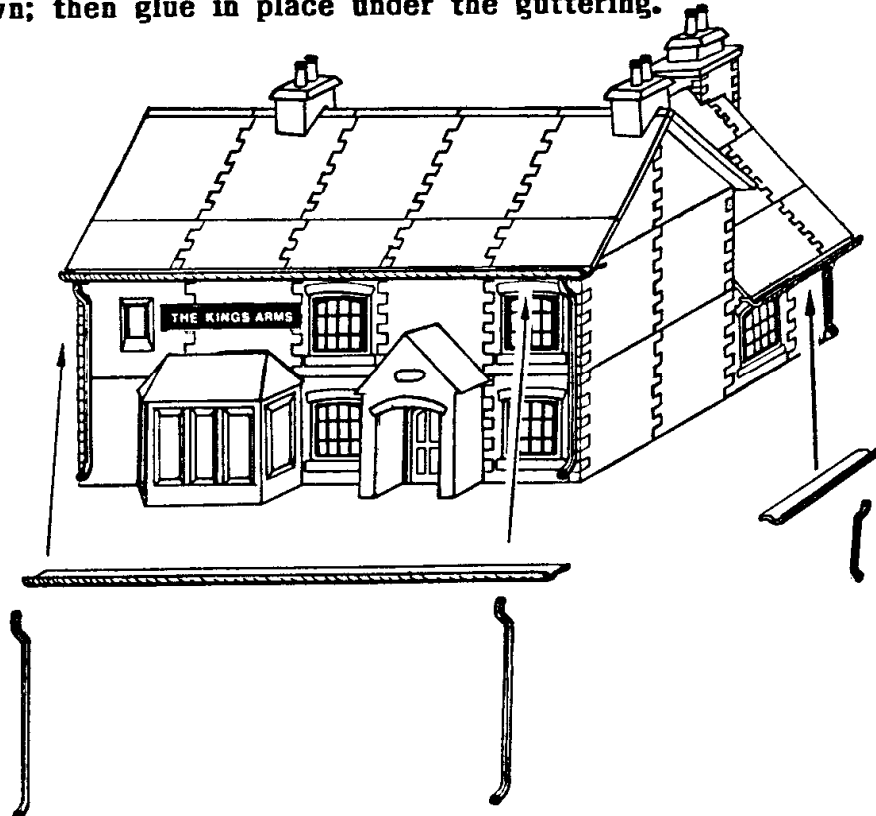

4) Prepare the undersides of the various rear roofs for guttering by sanding the bottom edges horizontal.

5) Cut pieces of plastic guttering to the various lengths; then glue in place under the eaves.

6) Cut pieces of plastic drainpipe to various lengths and bend, as shown below, then glue in place under the guttering.

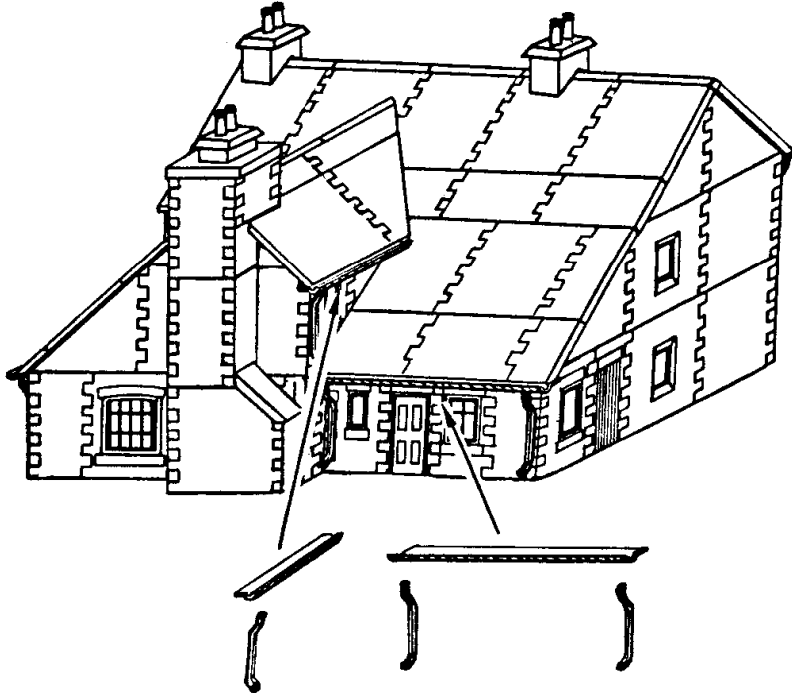

FINISHING:

For the final finishing and weathering of the model, switch to watercolour paint, in either powder, tube or block form. With a well diluted mix of grey watercolour, paint the entire stonework area; when dry, some of the paint will have collected in the mortar runs to represent cement. If it has 'greyed' the stonework too much, sponge off the excess. Repeat with a black wash for the roof. This process can be repeated for heavier weathering effects, or washed off and re-applied for any change of effect.

Adding a beer garden and car park to the completed inn can be fun - casts from moulds S1 and S3 can be used for the walls and coping. A kit of scenic materials for grass, gravel, and foliage is available from Linka. Even miniature drinkers at various stages of inebriation are available!